

**CRN 95**

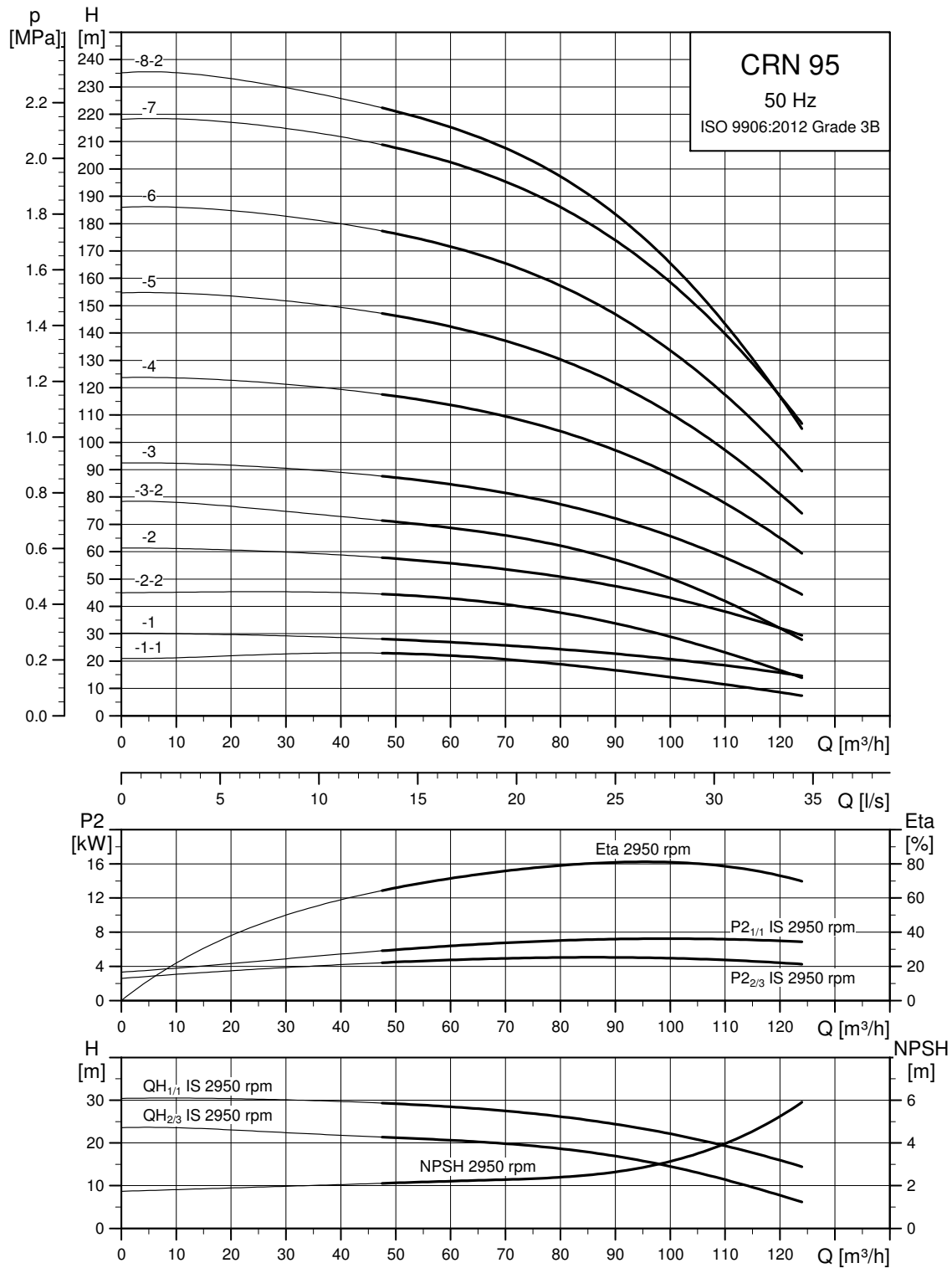

The maximum pump efficiency (ETA) is based on a three-stage pump.

TM06 5125 1318

Dimensional sketch

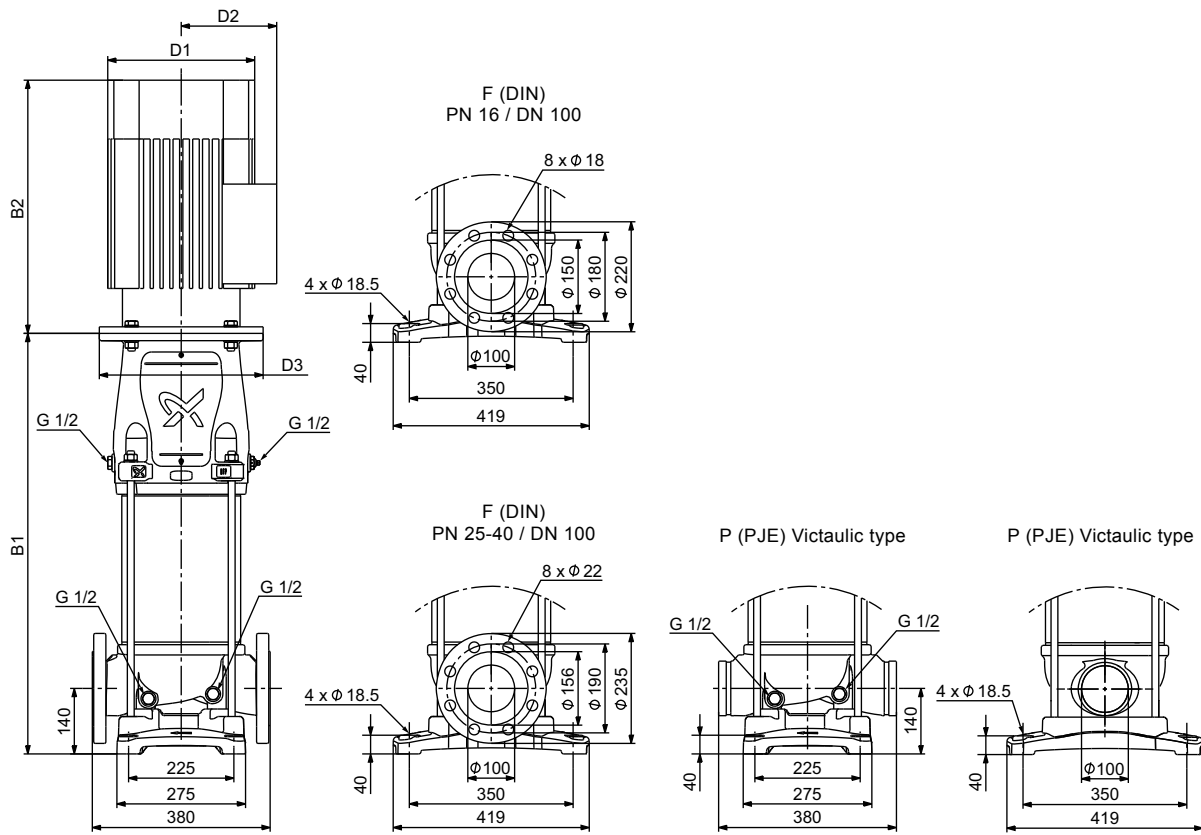

TM06 5094 1917

Dimensions and weights

Pump type	Motor P <sub>2</sub> [kW]	CRN					Net weight [kg]
		B1	B1+B2	D1	D2	D3	
CRN 95-1-1	5.5	689	1080	220	134	300	125
CRN 95-1	7.5	689	1068	260	159	300	135
CRN 95-2-2	11	795	1266	314	204	350	182
CRN 95-2	15	795	1266	314	204	350	193
CRN 95-3-2	18.5	900	1415	314	204	350	212
CRN 95-3	22	900	1441	314	204	350	227
CRN 95-4	30	1009	1620	396	315	400	349
CRN 95-5	37	1114	1750	396	315	400	380
CRN 95-6	45	1238	1946	449	338	450	462
CRN 95-7	55	1342	2089	497	410	550	562
CRN 95-8-2	55	1446	2193	497	410	550	568