

3642/3742

CLOSE-COUPLED AND FRAME-MOUNTED CENTRIFUGAL PUMPS



FEATURES

Compact Design: Close coupled, space saving design provides easy installation. Flexible couplings and bedplates not required.

Mounting: Can be mounted in vertical or horizontal position.

Construction: Available in bronze fitted (BF), all iron (AI), or all bronze (AB). Bronze fitted means bronze impeller.

Impeller: Enclosed design for high efficiencies. Threaded directly on motor shaft. Stainless steel locknut on three phase models requires no clearance adjustments. Balanced for smooth operation.

Casing: Volute type, cast iron or brass construction. Back pullout design. Discharge can be rotated in eight positions. Vertical discharge standard. Tapped openings provided for priming, venting and draining.

Mechanical Seal: Standard carbon/ ceramic faces, BUNA elastomers, 300 series stainless steel components. Option seals available.

Motor: Close-coupled design. Ball bearings carry all radial/axial thrust loads. Designed for continuous operation. All ratings are within working limits of the motor.

Frame-Mounted Design: Offers flexibility of installation and driver arrangements. Cast Iron Power Frame rigidly supports the grease-for-life ball bearing shaft assembly.

OPTIONAL MECHANICAL SEALS

Suffix	Rotary	Materials			Part No.	Seal Type	Service
		Stationary	Elastomer	Metal Parts			
Blank	Carbon	Ceramic	BUNA	316 SS	10K10	6	General
N		Ni-Resistant		18-8 SS	10K6		Fluct. Temp. up to 212°F
O		Sil-Carbide	EPR	316 SS	10K18	21	Hot Water up to 250°F
V			Viton		10K55		Mild Chemical

NOTE: To order an Optional Mechanical Seal, add appropriate suffix to order number. "N" for 10K6; "O" for 10K18 and "V" for 10K55. 10K55 replaces 10K24. The 10K55 has a 150 PSI rating, note that the pump's maximum working pressure is only 125 PSI.

3642/3742 NUMBERING SYSTEM

The various versions of the 3642 and 3742 are identified by a product code number on the pump label. This number is also the catalog number for the pump. The meaning of each digit in the product code number is shown below.

3500 RPM CLOSE COUPLED

Example Product Code 1BF11512

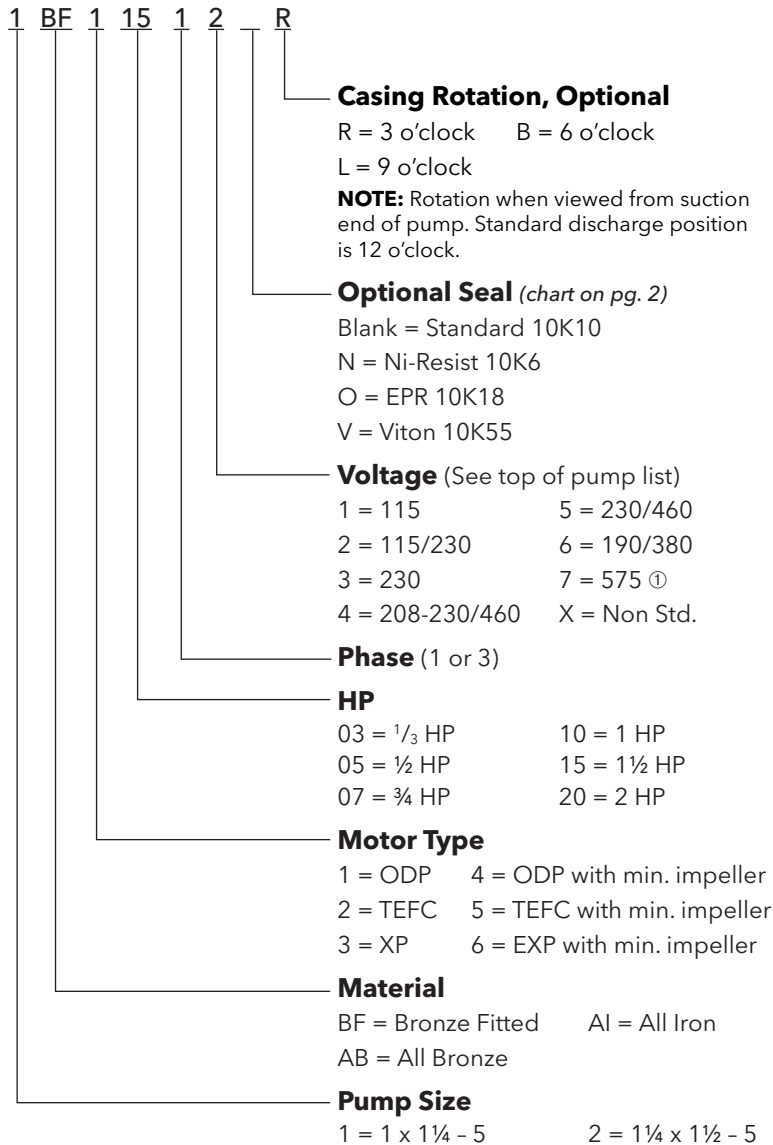

FRAME MOUNTED PUMPS ONLY

Example Product Code F1BF05

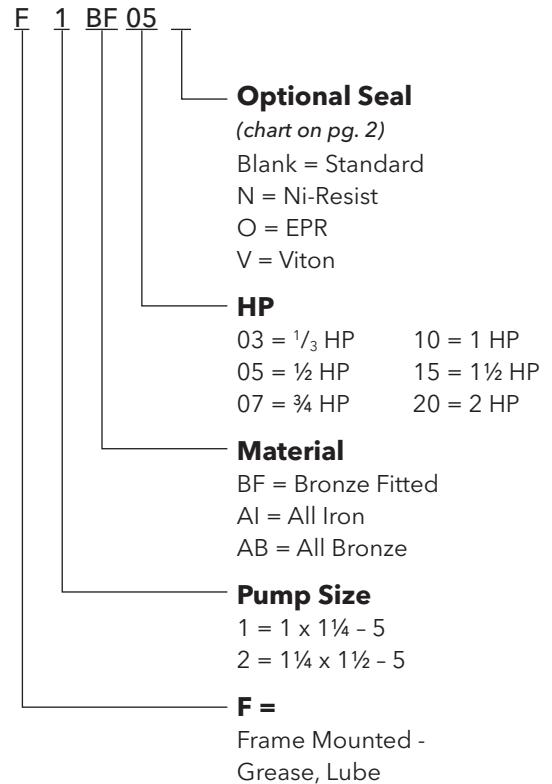

① 575 Volt motors have an extended lead time.

NOTE: Not recommended for operation beyond printed H-Q curve. For critical application conditions consult factory.

NOTE: Not all combinations of motor, impeller and seal options are available for every pump model. Contact Customer Service for information on non-cataloged order numbers.

NOTE: Impellers will be trimmed in 1/16" increments only. If you are ordering a trim within 1/16" of the standard impeller, you will receive the standard impeller trim.

PERFORMANCE CURVE 1AI, 1BF, 1AB ...

MOTOR SIZES* AND IMPELLER DIAMETERS

① 1½ HP ODP OR 2 HP TEFC	5⅝" DIA.	④ ½ HP ODP OR ¾ HP TEFC	3⅞" DIA.
② 1 HP ODP OR 1½ HP TEFC	5⅜" DIA.	⑤ ¼ HP ODP OR ½ HP TEFC	3⅞" DIA.
③ ¾ HP ODP OR 1 HP TEFC	4⅞" DIA.	⑥ OPTIONAL TRIMMED IMPELLER	3⅞" DIA.

* Premium efficiency where Department of Energy regulations apply.
Consult factory for dimensions.

*Eficacia superior donde el Ministerio de regulaciones de la Energía se aplica.
Consulte la fábrica para las dimensiones.*

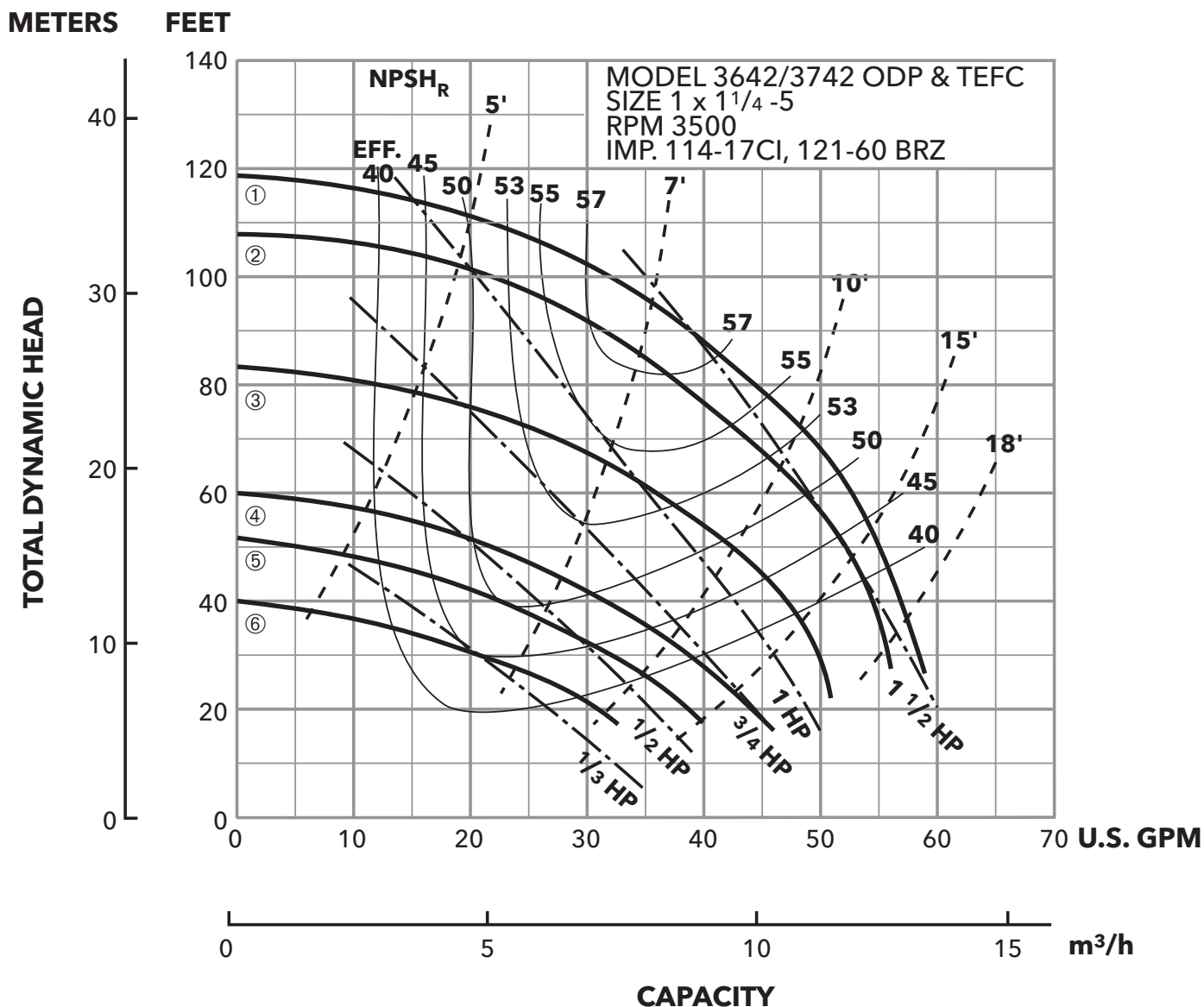

PERFORMANCE CURVE 2AI, 2BF, 2AB ...

MOTOR SIZES* AND IMPELLER DIAMETERS

① 2 HP ODP	5" DIA.	④ ¾ HP ODP OR 1 HP TEFC	3½" DIA.
② 1½ HP ODP OR 2 HP TEFC	4¾" DIA.	⑤ ½ HP ODP OR ¾ HP TEFC	3⅛" DIA.
③ 1 HP ODP OR 1½ HP TEFC	3⅞" DIA.	⑥ OPTIONAL TRIMMED IMPELLER	2⅞" DIA.

* Premium efficiency where Department of Energy regulations apply.
Consult factory for dimensions.

*Eficacia superior donde el Ministerio de regulaciones de la Energía se aplica.
Consulte la fábrica para las dimensiones.*

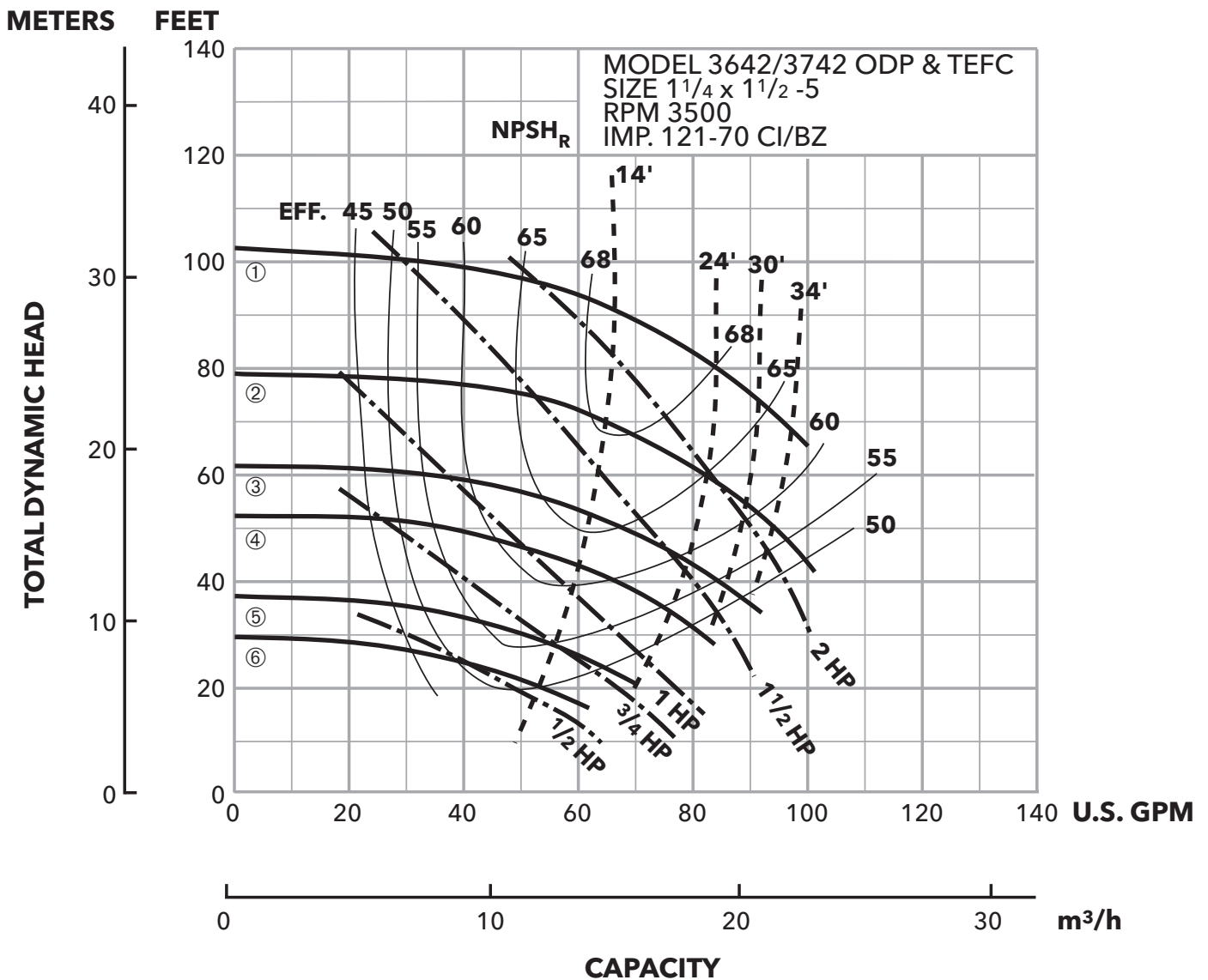

CLOSE-COUPLED

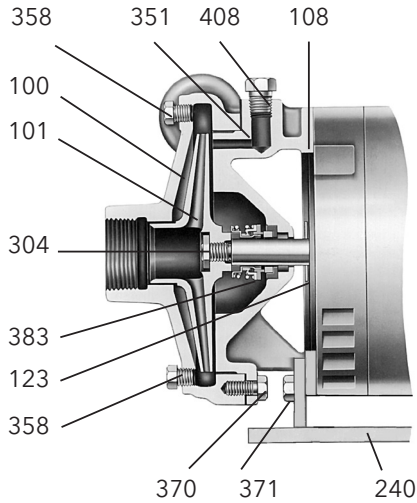

MOTOR FRAME

Motor Frame	Single Phase		Three Phase	
	ODP*	TEFC*	ODP*	TEFC/EXPL*
48	1/3	-	-	-
56	1/2 - 2	1/2 - 2	1/3 - 2	1/2 - 2

* Premium efficiency where Department of Energy regulations apply. Consult factory for dimensions.

Eficacia superior donde el Ministerio de regulaciones de la Energía se aplica. Consulte la fábrica para las dimensiones.

MATERIALS OF CONSTRUCTION

Item No.	Description	Material Code		
		Bronze Fitted	All Iron	All Bronze
100	Casing	1001	1001	1101
101	Impeller	1101	1001	1101
108	Adapter	1001	1001	1101
123	Water deflector	Rubber or Micarta®		
240	Motor Support	Steel		
	Rubber Channel	Rubber		
304	Impeller nut*	Stainless steel		
351	Gasket-casing	Composite		
358	Pipe plug 1/4" vent and drain	Brass	Steel	Brass
370	Hex head cap screw adapter to case	Zinc-Plated Steel		
371	Hex head cap screw adapter to motor	Zinc-Plated Steel		
383	Mechanical Seal	See Nomenclature		
408	Prime plug - priming 1/4" NPT	Brass	Steel	Brass

* Impeller nut furnished on three phase units only.

Material Code	Engineering Standard
1001	Cast iron ASTM A48 CL 20
1101	Bronze ASTM B584, C87500 Lead-Free

**Mechanical Seal Item 383						
Part No.	Service	Rotary	Stationary	Elastomer	Metal Parts	Crane Type
10K10	Standard Duty	Carbon	Ceramic	BUNA	316 SS	6
10K6	Fluct. Temp up to 212° F		Ni-Resist		18-8 SS	
10K18	Hot Water up to 250° F		Sil.-Carbide	EPR	316 SS	21
10K55	Mild Chemical		Ceramic	Viton		

FRAME-MOUNTED

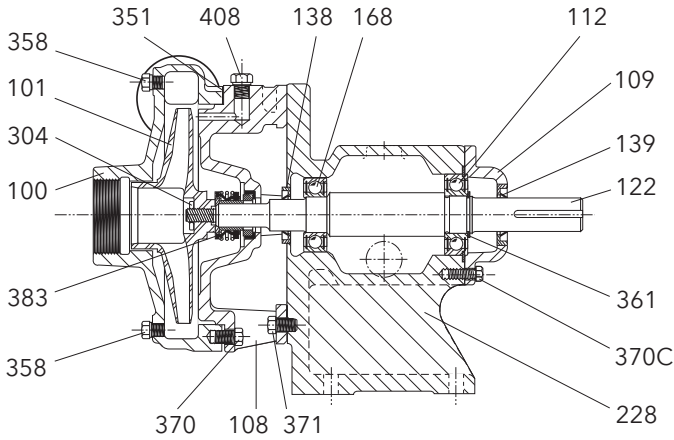

MATERIALS OF CONSTRUCTION

Item No.	Description	Material Code		
		Bronze Fitted	All Iron	All Bronze
100	Casing	1001	1001	1101
101	Impeller	1101	1001	1101
108	Adapter Frame	1001	1001	1101
109	Bearing Cover	1001	1001	1001
112	Ball Bearing (outboard)	Steel		
122	Shaft	AISI 303 SS		
138	Lip-seal (inboard)	BUNA/Steel		
139	Lip-seal (outboard)	BUNA/Steel		
168	Ball Bearing (inboard)	Steel		
228	Bearing Frame	Cast Iron		
304	Impeller Locknut	AISI 416 SS		
351	Gasket	Composite		
358	Drain and Vent Plug, Casing	Plated Steel or Brass		
361	Retaining Ring	Steel		
370	Socket, Head Screw, Casing	Plated Steel		
370C	H.H. Screw, Bearing Cover	Plated Steel		
371	H.H. Screw, Bearing Frame	Plated Steel		
383	Mechanical Seal	**See Chart		
408	Priming Plug	Plated Steel or Brass		

Material Code	Engineering Standard
1001	Cast iron ASTM A48 CL 20
1101	Bronze ASTM B584, C87500 Lead-Free

**Mechanical Seal Item 383						
Part No.	Service	Rotary	Stationary	Elastomer	Metal Parts	Crane Type
10K10	Standard Duty	Carbon	Ceramic	BUNA	316 SS	6
10K6	Fluct. Temp up to 212° F		Ni-Resist		18-8 SS	
10K18	Hot Water up to 250° F		Sil.-Carbide	EPR	316 SS	21
10K55	Mild Chemical		Ceramic	Viton		

3642 DIMENSIONS AND WEIGHTS

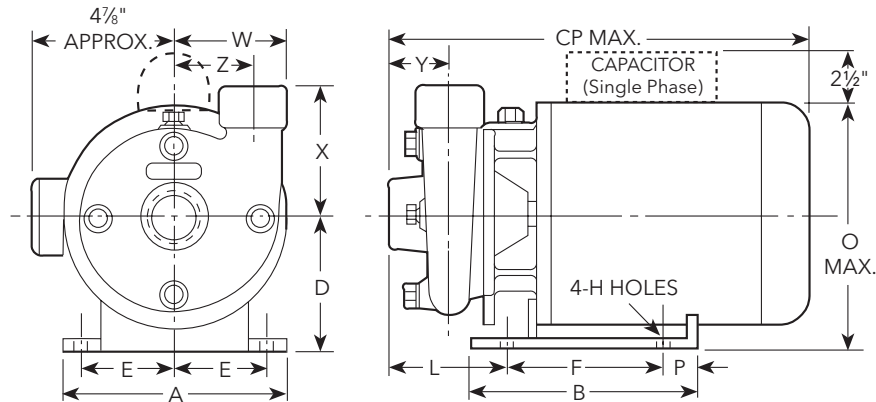

Pump	A	B	D	E	F	H	L	O	P	W	X	Y	Z	CP	Motor Frame	Wt. (lbs.)
1x1 1/4-5	6 3/4	5 7/8	4 1/8	2 1 5/16	5	1 3/32	3 3/8	7	7/16	4	4 1/8	2 3/16	3 1/16	13	48	55
1 1/4 x 1 1/2 - 5							3 3/8	7 3/8			4	2 1/4	2 1 5/16	17 11/16	56	67

3742 BARE PUMP DIMENSIONS AND WEIGHTS

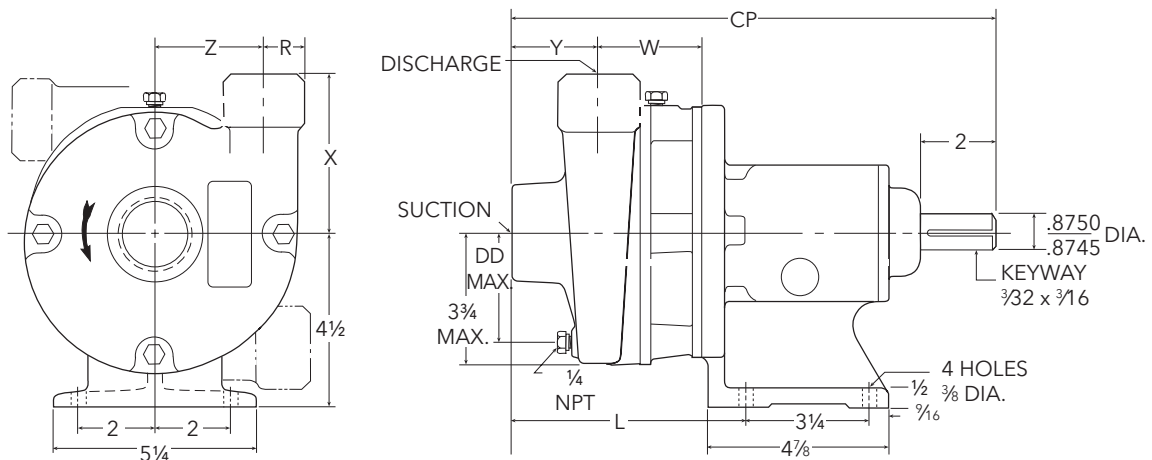

Pump	Suction*	Discharge*	CP	DD Max.	L	R	W	X	Y	Z	Wt. (lbs.)
1 x 1 1/4 - 5	1 1/4	1	12 1/4	3 1/4	5 13/16	1 5/16	2 1/2	4 1/8	2 3/16	3 1/16	45
1 1/4 x 1 1/2 - 5	1 1/2	1 1/4	12 1/2	3 3/8	6 1/8	1 1/16	2 3/4	4	2 1/4	2 1 5/16	48

* NPT Connections

NOTES:

- Pumps will be shipped with top vertical discharge as standard. For other orientations, remove casing bolts, rotate to desired position, replace and tighten 3/8 - 16 bolts to 37 lb./ft.
- Not to be used for construction purposes.
- Dimensions in inches

3742 DIMENSION PRINT

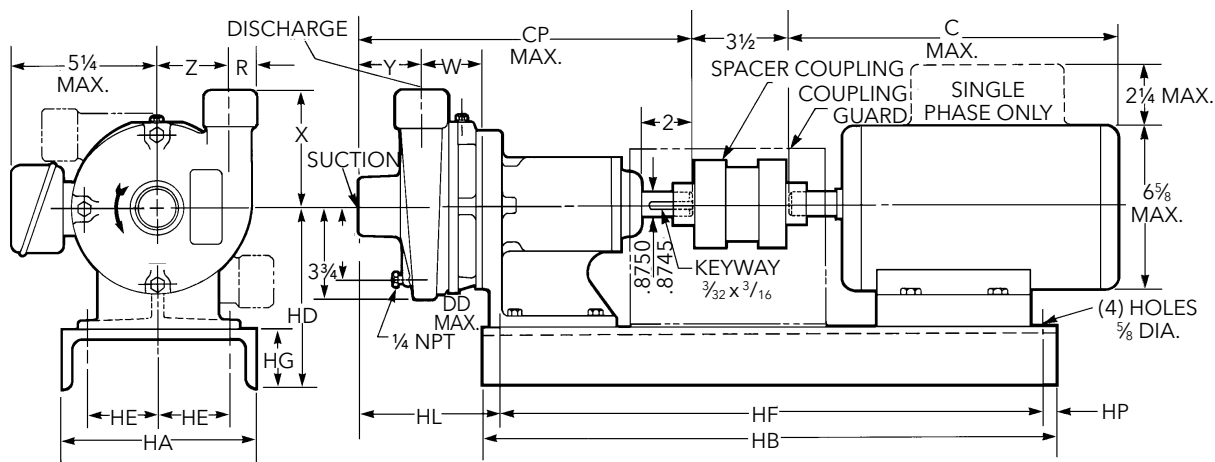

WEIGHTS AND DIMENSIONS - DETERMINED BY PUMP

Pump Size	Suction NPT	Discharge NPT	CP	DD Max.	R	W	X	Y	Z	Wt. (lbs.)	Dim. "HL" Determined by Pump and Bedplate		
											56	140	180
1 x 1 1/4-5	1 1/4	1	12 1/4	3 3/4	1 5/16	2 1/2	4 1/8	2 3/16	3 1/16	45	4	5 7/8	
1 1/4 x 1 1/2-5	1 1/2	1 1/4	12 1/2	3 3/8	1 1/16	2 3/4	4	2 1/4	2 15/16	48	4 1/4	6 1/8	

NOTE: All pumps shipped in vertical discharge position. May be rotated in 90° increments. Tighten 3/8 -16 casing bolts to 37 ft./lbs. torque.

AVAILABLE MOTOR AND BEDPLATE WEIGHTS AND DIMENSIONS

Motor Frame	HP @ 3500 RPM				C Max.	Wt. Max.	Bedplate Data							
	1 Phase		3 Phase				HA	HB	HD	HE	HF	HG	HP	Wt. (lbs.)
	ODP*	TEFC*	ODP*	TEFC*										
56	1/2 or 1 1/2	1/2 or 1 1/2	1/2 or 1	1/2 or 1	13	45	8	26	6 7/8	3 3/8	22 3/8	2 3/8	1	30
143T			1 1/2	1 1/2	13 3/8									
145T	2	2	2 or 3	2	14 1/4	52	10		7 1/4	3 3/4	24	2 3/4	7/8	43
182T	3	3		3	16 5/8	63								

NOTE: Dimensions and weights vary with manufacturers. Dimensions in inches and weights in lbs.

* Premium efficiency where Department of Energy regulations apply. Consult factory for dimensions.

Eficacia superior donde el Ministerio de regulaciones de la Energía se aplica. Consulte la fábrica para las dimensiones.

APPLICATIONS

Specifically designed for the following uses:

- Water circulation
- Booster service
- Liquid transfer
- Spraying systems
- Jockey pump service
- General purpose pumping

SPECIFICATIONS

Pump

- Capacities: to 110 GPM
- Heads: to 118 feet
- Pipe connections:

Model	Suction	Discharge
1 x 1¼ - 5	1¼" NPT	1" NPT
1¼ x 1½ - 5	1½" NPT	1¼" NPT

- Maximum working pressure: 125 PSI
- Temperature: standard seal, 212° F (100° C) maximum or 250° F (121° C) with optional high temperature seal.
- Rotation: right hand i.e.; clockwise when viewed from motor end.

Motor

- NEMA standard
- Open drip proof*, TEFC*, or (explosion proof three phase only) enclosures*.
- 60 Hz, 3500 RPM
- Stainless steel shaft
- Single phase: ½-2 HP ODP* or TEFC*. Built-in overload with automatic reset.
- Three phase: ⅓ - 2 HP: ODP*, 208-230/460 V
½ - 2 HP: TEFC*, 208-230/460 V
½ - 2 HP: expl. proof*, 230/460 V
- NEMA 56J frame motors are used on close-coupled 3642 pumps and T-frame motors are used on frame-mounted 3742 pumps.
- Overload protection must be provided in starter unit. Starter and heaters (3) must be ordered separately.

* Premium efficiency where Department of Energy regulations apply. Consult factory for dimensions.

Xylem |'zīləm|

- 1) The tissue in plants that brings water upward from the roots;
- 2) a leading global water technology company.

We're a global team unified in a common purpose: creating innovative solutions to meet our world's water needs. Developing new technologies that will improve the way water is used, conserved, and re-used in the future is central to our work. We move, treat, analyze, and return water to the environment, and we help people use water efficiently, in their homes, buildings, factories and farms. In more than 150 countries, we have strong, long-standing relationships with customers who know us for our powerful combination of leading product brands and applications expertise, backed by a legacy of innovation.

For more information on how Xylem can help you, go to www.xylem.com



Xylem Inc.
2881 East Bayard Street Ext., Suite A
Seneca Falls, NY 13148
Phone: (800) 453-6777
Fax: (888) 322-5877
www.gouldswatertechnology.com

Goulds is a registered trademark of Goulds Pumps, Inc. and is used under license.
© 2016 Xylem Inc. B36/3742 R3 June (Junio) 2016